



AZALEA

TOWNHOMES AT BLOOMDALE

CONTEMPORARY
LIVING
BY NOSTRA



Welcome to Azalea at Bloomdale

A collection of eight stunning three and four bedroom residences await you at Bloomdale.

Built by Nostra, these architecturally designed park fronted homes feature a modern exterior richly complimented by well crafted and spacious interiors. Providing the very best of turn-key features without compromising on quality, the Azalea Townhomes at Bloomdale are the perfect start to your next chapter in life.

Artist impression



A place with everything.

Nestled right between Melbourne and the Macedon Ranges, Bloomdale is a short drive from Sunbury and Watergardens Town Centre.

Right from the start, enjoy sporting and recreation facilities including football ovals, tennis courts and parks. With the Calder Freeway and Diggers Rest train station nearby, proximity is assured with access to the CBD and wider Melbourne.



Shopping will be at your door, with the future Bloomdale Town Centre, which will include a supermarket, general retail, community meeting space and much more.

Bloomdale offers over 6 hectares of parks, interconnected with over 40km of bike trails and shared walking paths providing a balanced and outdoor lifestyle.



AZALEA
AT BLOOMDALE

FUTURE
DEVELOPMENT
BY OTHERS

Future
Development
by AVID

Future Walking

BY OTHERS

EMPLOYMENT
AREA

FUTURE
EMPLOYMENT

EMPLOYMENT
AREA



The Azalea Release is the perfect choice.

Located in stage 39 at Bloomdale, the Azalea Release provides one of the final opportunities to purchase within Bloomdale. Located fronting a spacious park and with close proximity to the linear reserve with its meandering paths and waterways, these stunning homes with an architecturally designed streetscape will provide a perfect picture upon completion.

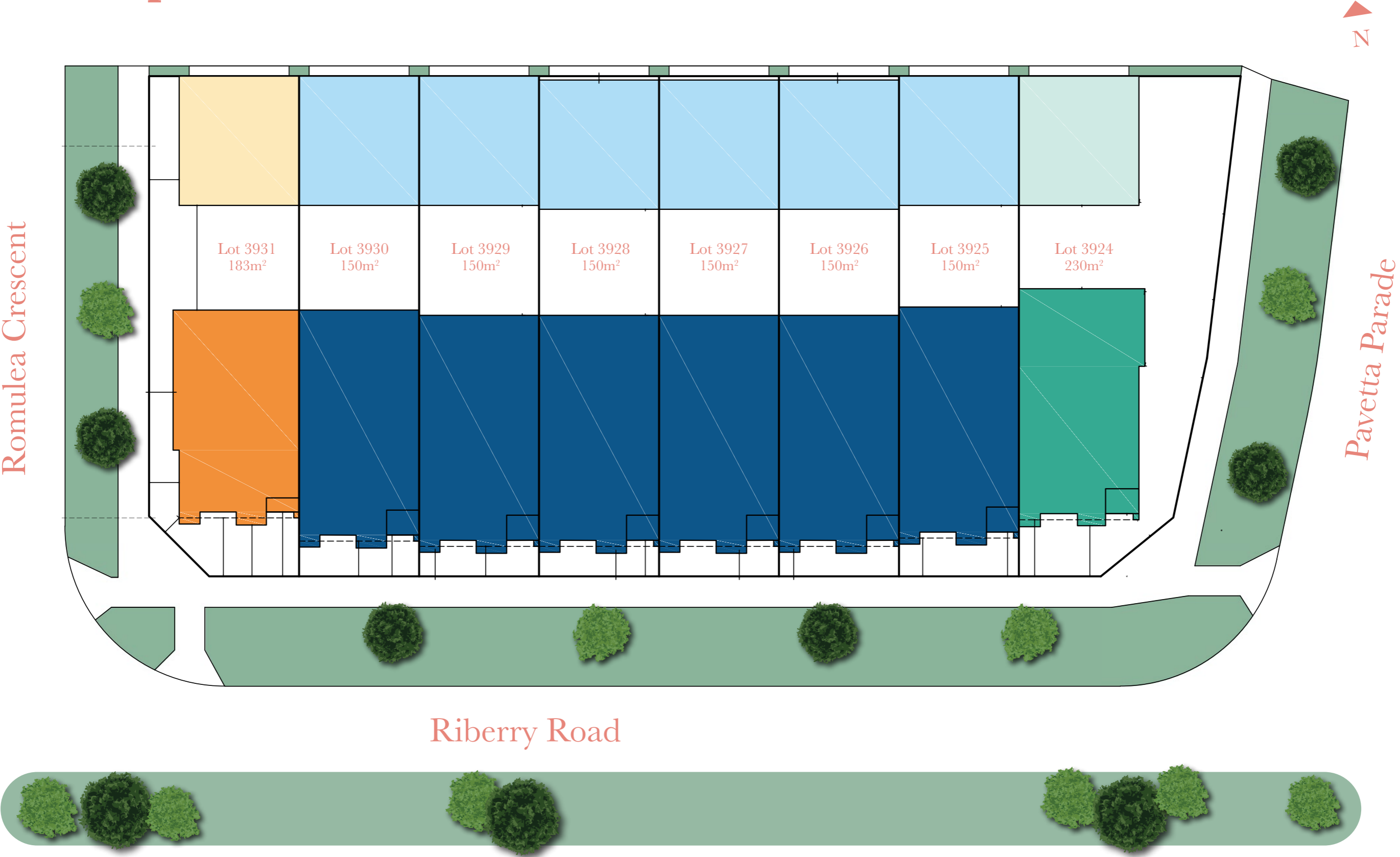

Ready to move in



Lot 3931

Lot 3930

Lot 3929

Lot 3928

Lot 3927

Lot 3926

Lot 3925

Lot 3924

Inclusions

- ▶ Turn-key Inclusions
- ▶ Flooring throughout the home
- ▶ Architecturally designed facades
- ▶ Stainless steel appliances including dishwasher
- ▶ 2590mm high ceilings to ground floor
- ▶ Fencing to all side and rear boundaries
- ▶ Low maintenance landscaping
- ▶ LED Downlights to main living area
- ▶ No Body Corporate

Artist impression



Floorplans

Lot 3924 | Inverloch | 19sq

4  2  2 

Refer to individual plans for orientation

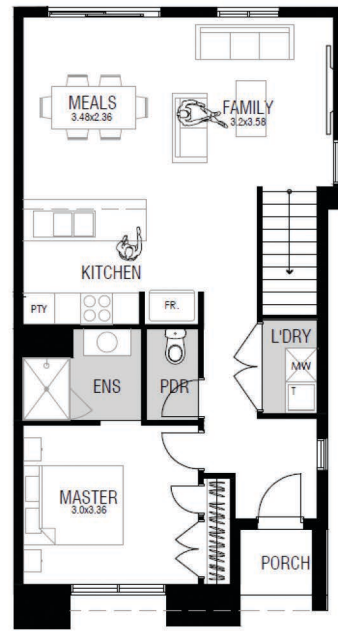

Ground Floor

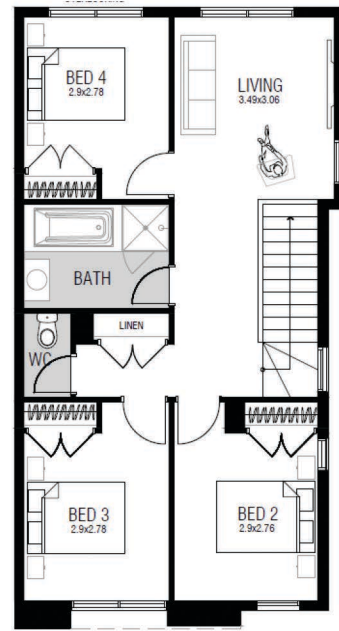

First Floor

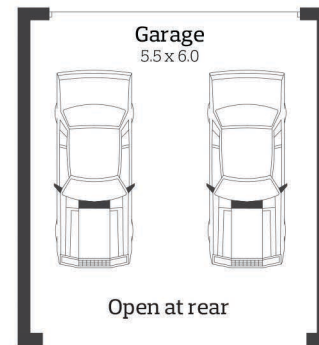

This plan and information is indicative only and may vary without notice. Furniture and vehicles are not included in the sale. Garage not in position.

Lot 3925-3930 | Inverloch | 19sq

4  2  2 

Refer to individual plans for orientation



Ground Floor

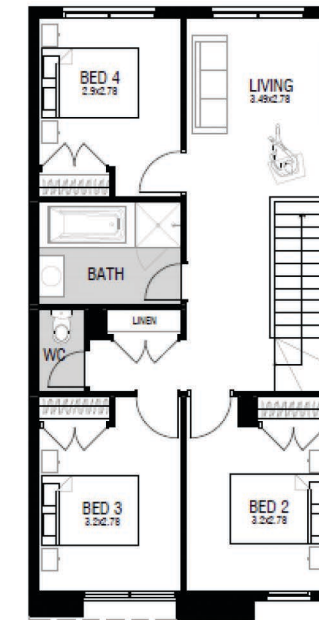

First Floor

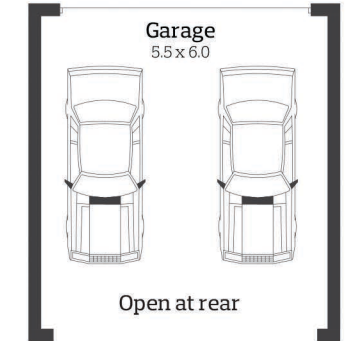

This plan and information is indicative only and may vary without notice. Furniture and vehicles are not included in the sale. Garage not in position.



The image depicted here is indicative only. Facade finishes and colouring may vary.



The image depicted here is indicative only. Facade finishes and colouring may vary.

Floorplans

Lot 3931 | Elwood | 18sq

3  2  2 

Refer to individual plans for orientation

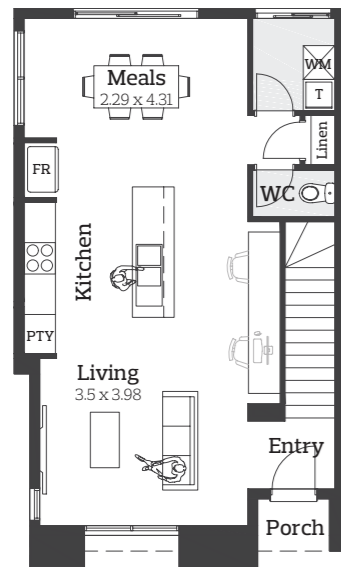

Ground Floor

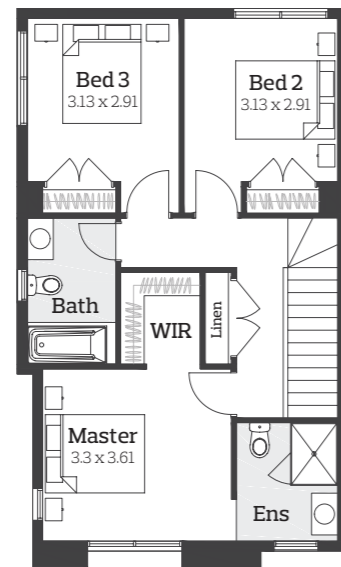

First Floor

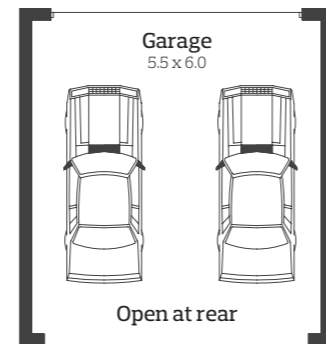

This plan and information is indicative only and may vary without notice. Furniture and vehicles are not included in the sale. Garage not in position.



The image depicted here is indicative only. Facade finishes and colouring may vary.



Inclusions

General

25 year structural guarantee

Dwelling constructed independently

Connections

Garden tap

Stormwater drains

Sewer drains

Electricity, gas and water connections

Fibre optic provisions (does not include installation of Hub or final connections)

All connections exclude consumer connection fees and utility account opening fees

Foundations

Fixed site costs (rock Included and retaining walls if required only - not landscaping)

Engineered minimum 25mpa concrete slab 400mm thick

Framing

Stabilised pine steel or wall frames

Engineered designed roof trusses

Ceilings

2590mm height for single storey and ground floor of double storey designs with 2400mm for upper levels

90mm cove cornice throughout

Windows

Aluminium windows

Keyed locks to all windows

Facade

Facade as noted in approved architectural drawings

External Cladding

VBA compliant cladding

Roof Plumbing/Tiles

Fascia, gutter, downpipes and cappings with concrete roof tiles

Note: certain designs are zinc flat deck specific

Insulation/6 star

Sisalation wall wrap

Wall batts to external walls

Insulation wool to ceiling cavity of living areas

Gas solar hot water unit (note: when an estate requires recycled water connection, a gas continuous flow hot water unit will be supplied)

Garage

Panel lift COLORBOND garage door with 2 hand held and 1 wall mounted remote control

Stairs

MDF treads and risers with carpet (plan specific)

Doors/Furniture

Entry: 2040mm x 820mm Solid core door with Trilock entrance set

Internal: 2040mm high Flush panel doors with Brushed Chrome passage handles and air cushioned door stops

Chrome knob to robe cupboards

Skirting/Architraves

67mm x 18mm Primed MDF skirting and architraves

Tiled skirting 100mm to wet areas

Shelving

Robes: x 1 shelf with chrome hanging rails

Pantry: x 4 shelves

Linen: x 3 shelves

Ceilings

2590mm height ceilings

Electrical

LED downlights to main living areas on ground floor

Included

Only at Bloomdale

- ✓ LED Downlights to main living area
- ✓ 20mm stone to kitchen
- ✓ Garage door remote (x3) and motor to panel lift

Kitchen Benchtops

20mm stone benchtops

Flooring

Choice of ceramic 450x450mm floor tiles or timber laminate

Artist impression

Electrical

Safety switches (residual current devices)

Direct wired smoke detectors

Batten holders throughout

x1 rear flood light

Exhaust fans to areas with no openable window

1 x Double powerpoint to each room (refer to electrical Plans)

1 x Television and phone point (refer to electrical Plans)

Heating and Cooling

Flat Roof Design (refer to project plans)

Heating panels to all bedrooms and living area

Toilets

Dual flush cisterns with vitreous china pan

Toilet roll holders

Bathroom/Ensuite

Laminate cabinets and benchtops

Vitreous china designer basins with chrome flick mixers

White acrylic bath tub with chrome outlet and tap set with shower head and shower screen (floorplan specific)

Polished edge mirrors (size width of vanities)

Pre-formed shower base to all showers (refer to plans for size)

Framed pivot door screen to all showers
Wall mounted shower on rail with chrome mixer

Double towel rail holder

Designer pull handles

Kitchen

Australian made kitchen

Laminate panels and doors and benchtops

Feature shelves above bench

Double end bowl stainless steel sink with chrome mixer

Designer pull handles

Appliances

600mm stainless steel Technika:

- Built-in oven
- Electric cooktop
- Concealed undermount rangehood
- Dishwasher

Laundry

45L stainless steel tub with metal cabinet and chrome mixer

Floor Coverings

Ceramic floor tiles or timber laminate (please refer to standard floorplan for locations)

Ceramic floor tiles to bathroom, toilet, ensuite and laundry

Carpet to remainder (refer to standard plans)

Wall Tiles

Ceramic wall tiles to:
Above kitchen bench including behind feature shelving

2000mm to shower walls

Bath edge to floor

400mm above bathtub

Paint

Premium 3 coat wall & 2 coat ceiling paint system

High gloss enamel to all interior wood work and doors

2 coats to all exterior claddings

External

Concrete driveway (as per plan)

Full front and rear landscaping with drought resistant plants with pebbles and mulch

Fencing to all boundaries to developers requirements including wing gate where required (refer to plans)

Letterbox

Clothesline

(All external works to builders discretion and retaining walls to engineers requirements only)

Artist impression

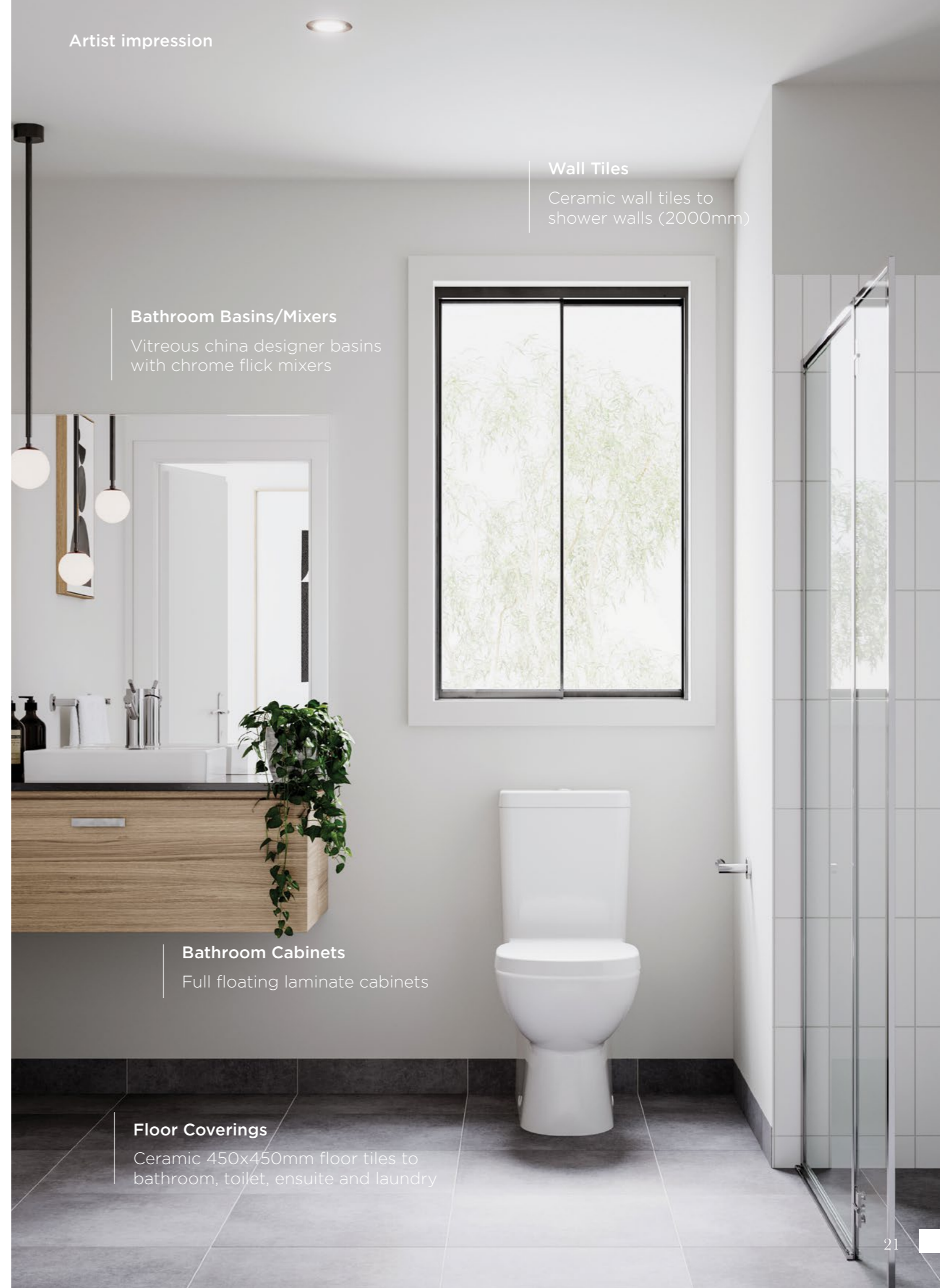

Wall Tiles

Ceramic wall tiles to shower walls (2000mm)

Bathroom Basins/Mixers

Vitreous china designer basins with chrome flick mixers

Bathroom Cabinets

Full floating laminate cabinets

Floor Coverings

Ceramic 450x450mm floor tiles to bathroom, toilet, ensuite and laundry

Interior styling at your finger tips

Your choice from two
stunning colour schemes.

01

MODE
Interior Design Scheme



02

LUXE
Interior Design Scheme

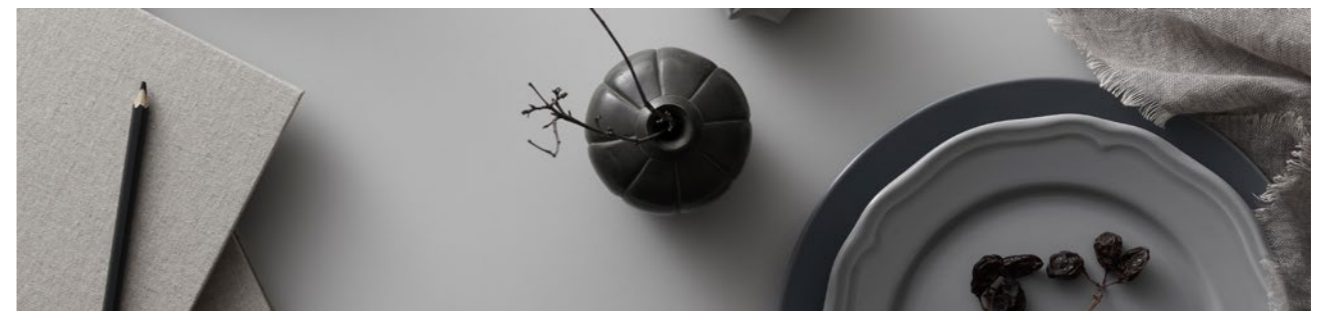
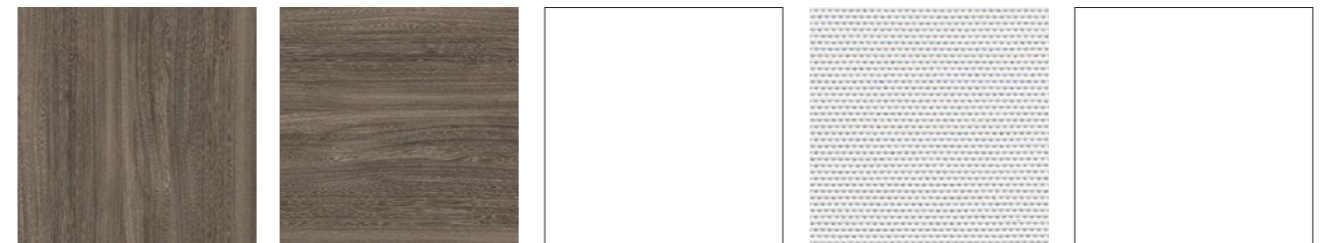

Why Nostra?



24/7 service through our dedicated online client portal



24/7 Emergency RACV home assist for the first 12 months after you move in for further peace of mind



More timber in our frames and stronger slabs that exceed industry standard



High quality materials from trusted brands



A strong level of inclusions from the start



Backed by a **25 year** structural guarantee!

Artist impression





Joint Partnership

NOSTRA

BUILDER

Specialising in modern turn-key living, Nostra have been building outstanding homes throughout Melbourne suburbs since 2006. Nostra maintains a focus on creating affordable homes that exceed the industry standard using only quality products that stand the test of time. With a high level of standard finishes, Nostra's Contemporary Living options stand out for value without compromising on quality.

AVID
Property Group

DEVELOPER

AVID Property Group (AVID) is an award-winning Australian developer responsible for a diversified portfolio of residential communities.

AVID creates communities that bring people together – to enhance their lives and the way they live. With a passion for sustainability, we deliver sustainable and progressive residential communities in key growth corridors across Australia.



AZALEA

AT BLOOMDALE

FOR MORE INFORMATION

Nostra Homes

Heru Harjanta
0427 875 118

PROUDLY DEVELOPED BY

NOSTRA



Disclaimer: Limited number of lots available and buyers of the lots must sign a building contract for the lot with the builder specified by the vendor. Prospective buyers should make and rely on their own enquiries and seek independent legal and financial advice. The information contained in this promotional material including statements, figures, images, and representations are indicative only, are current on the date of publication, and may change without notice. Images may include artist impressions and computer-generated images that are for general illustration purposes only, which may not be to scale and may differ from the final built form. Actual lots, stages, facilities, amenities, infrastructure, and their configuration are subject to statutory approval and may change. All persons should seek their own independent legal, financial, and real estate advice. This document is not a contract and is not binding. Your land sale contract will set out all binding terms relating to the lot, and your building contract with Nostra Homes and Development Pty Ltd will set out all binding terms for the build. Satterley Tarneit Derrimut Pty Ltd is the Project Manager for the Bluestone Estate. The Bluestone name is a registered trademark used under license © 2022. Nostra Homes and Developments Pty Ltd. ABN 66 127 679 627 is a Registered Building Practitioner.

Builder Licence Number CDB-U 48475.